

J 系列 - 臥式齒輪減速機馬達

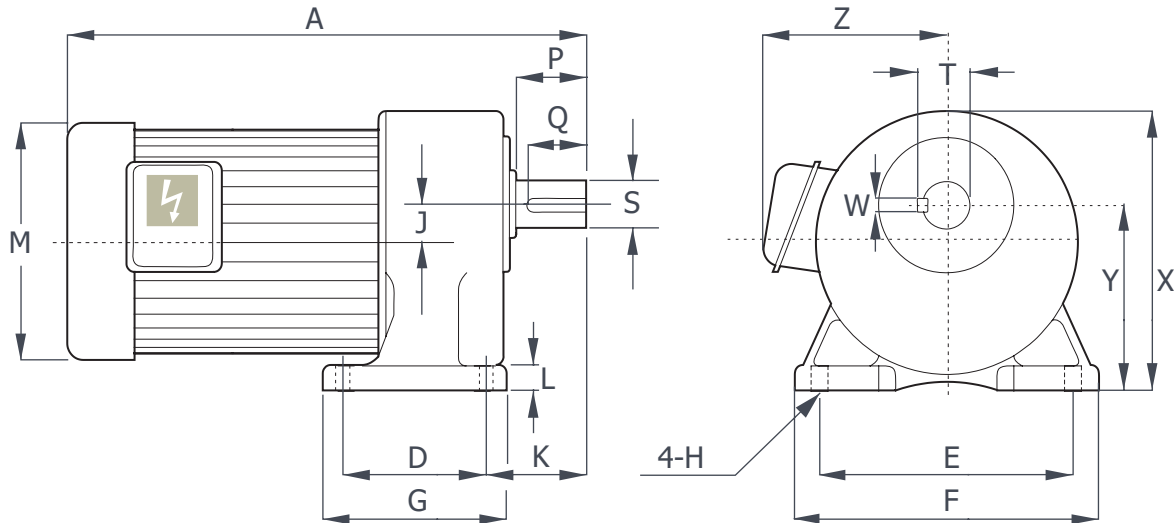

馬力 HP	減速比 Gear Ratio	A	D	E	G	F	H	L	J	K	M	X	Y	Z	出力軸端 Output Shaft End				
															P	Q	S	T	W
0.1KW 1/8 HP (4P)	5-50	245(270)	40	110	65	135	10	10	16	50	126	130	85	115	30	27	18	20	5
	60-200	245(270)	65	130	90	156	11	13	18	55	126	135	90	115	40	35	22	25	7
	250-1800	340(365)	90	140	120	170	11	14	22	65	126	164	110	115	45	40	28	31	7
0.2KW 1/4 HP (4P)	5-10	280(305)	40	110	65	135	10	10	16	50	126	130	85	115	30	27	18	20	5
	15-90	300(325)	65	130	90	156	11	13	18	55	126	135	90	115	40	35	22	25	7
	100-200	335(360)	90	140	120	170	11	14	22	65	126	164	110	115	45	40	28	31	7
	250-1800	405(430)	130	170	167	208	13	17	27	73	126	197	130	115	55	50	32	35.5	10
0.4KW 1/2 HP (4P)	5-10	325(375)	65	130	90	156	11	13	18	55	142	135	90	120	40	35	22	35	7
	15-90	360(410)	90	140	120	170	11	14	22	65	142	164	110	120	45	40	28	31	7
	100-200	390(440)	130	170	167	208	13	17	27	73	142	197	130	120	55	50	32	35.5	10
	250-1800	480(530)	150	210	198	252	15	18	32.5	93	142	227	150	120	65	60	40	43.5	10
0.75KW 1 HP (4P)	5-25	375(425)	90	140	120	170	11	14	22	65	156	164	110	130	45	40	28	31	7
	30-120	410(460)	130	170	167	208	13	17	27	73	156	197	130	130	55	50	32	35.5	10
	125-200	450(500)	150	210	198	252	15	18	32.5	93	156	227	150	130	65	60	40	43.5	10
	250-1800	570(620)	160	230	201	291	18	25	40	100	156	267	170	130	75	70	50	53.5	14
1.5KW 2 HP (4P)	5-30	420(470)	130	170	167	208	13	17	27	73	179	197	130	145	55	50	32	35.5	10
	40-100	460(510)	150	210	198	252	15	18	32.5	93	179	227	150	145	65	60	40	43.5	10
	120-200	470(520)	150	210	198	252	15	18	32.5	93	179	227	150	145	65	60	40	43.5	10
	250-900	580(630)	160	230	201	291	18	25	40	100	179	267	170	145	75	70	50	53.5	14
2.2KW 3 HP (4P)	5-30	475(525)	150	210	198	252	15	18	32.5	93	179	227	150	160	65	60	40	43.5	10
	40-120	485(535)	160	230	201	291	18	25	40	100	179	267	170	160	75	70	50	53.5	14
3.7KW 5 HP (4P)	5-30	610(680)	160	230	201	291	18	25	40	100	208	267	170	160	75	70	50	53.5	14

* All Specifications, dimensions and design characteristics shown in this catalogue are subject to change without notices.

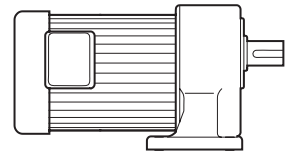
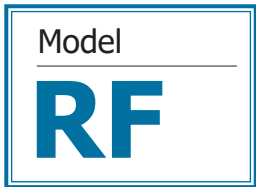

J 系列 - 立式齒輪減速機馬達

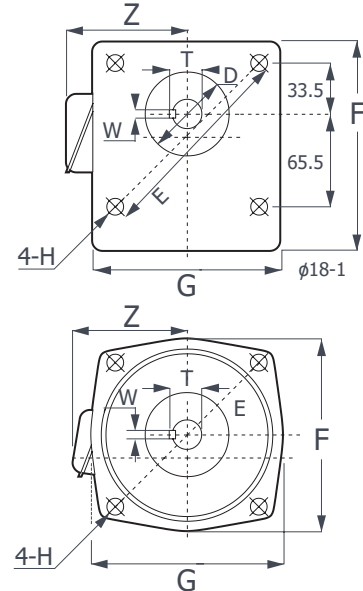
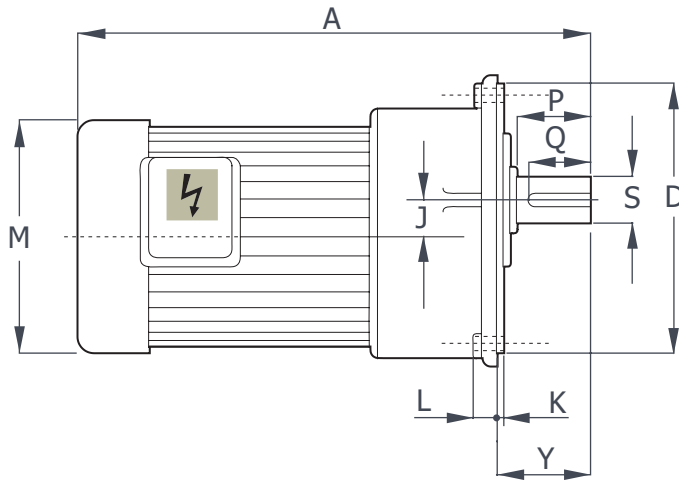
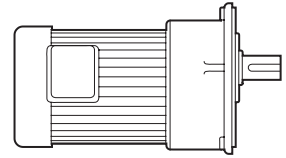

馬力 HP	減速比 Gear Ratio	A	D	E	G	F	H	L	J	K	M	Y	Z	出力軸端 Output Shaft End				
														P	Q	S	T	W
0.1KW 1/8 HP (4P)	5-50	260(280)	50	140	120	120	10	13	16	4	126	36	115	30	27	18	20	5
	60-200	290(310)	148	185	165	165	11	12	18	4	126	46	115	40	35	22	25	7
	250-1800	340(365)	170	215	193	198	11	14	22	4	126	52	115	45	40	28	31	7
0.2KW 1/4 HP (4P)	5-10	280(320)	50	140	120	120	10	13	16	4	126	36	115	30	27	18	20	5
	15-90	310(340)	148	185	165	165	11	12	18	4	126	46	115	40	35	22	25	7
	100-200	323(352)	170	215	193	198	11	14	22	4	126	52	115	45	40	28	31	7
	250-1800	435(450)	180	250	215	230	13	15	27	5	126	62	115	55	50	32	35.5	10
0.4KW 1/2 HP (4P)	5-10	330(360)	148	185	165	165	11	12	18	4	142	46	120	40	35	22	35	7
	15-90	332(364)	170	215	193	198	11	14	22	4	142	52	120	45	40	28	31	7
	100-200	395(445)	180	250	215	230	13	15	27	5	142	62	120	55	50	32	35.5	10
	250-1800	480(580)	230	310	265	285	15	20	32.5	5	142	72	120	65	60	40	43.5	10
0.75KW 1 HP (4P)	5-25	371(398)	170	215	193	198	11	14	22	4	156	52	130	45	40	28	31	7
	30-120	410(460)	180	250	215	230	13	15	27	5	156	62	130	55	50	32	35.5	10
	125-200	465(505)	230	310	265	285	15	20	32.5	5	156	72	130	65	60	40	43.5	10
	250-1800	570(620)	270	360	300	325	22	22	40	5	156	83	130	75	70	50	53.5	14
1.5KW 2 HP (4P)	5-30	420(470)	180	250	215	230	13	15	27	5	179	62	145	55	50	32	35.5	10
	40-100	460(510)	230	310	265	285	15	20	32.5	5	179	72	145	65	60	40	43.5	10
	120-200	470(520)	230	310	265	285	15	20	32.5	5	179	72	145	65	60	40	43.5	10
	250-900	580(630)	270	360	300	325	22	22	40	5	179	83	145	75	70	50	53.5	14
2.2KW 3 HP (4P)	5-30	475(525)	230	310	265	285	15	20	32.5	5	179	82	160	65	60	40	43.5	10
	40-120	485(535)	270	360	300	325	22	22	40	5	179	83	160	75	70	50	53.5	14
3.7KW 5 HP (4P)	5-30	610(680)	270	360	300	325	22	22	40	5	208	83	160	75	70	50	53.5	14

* All Specifications, dimensions and design characteristics shown in this catalogue are subject to change without notices.

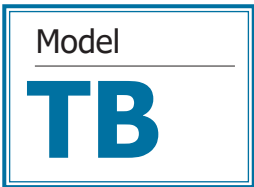

J系列 - 臥式雙軸型齒輪減速機

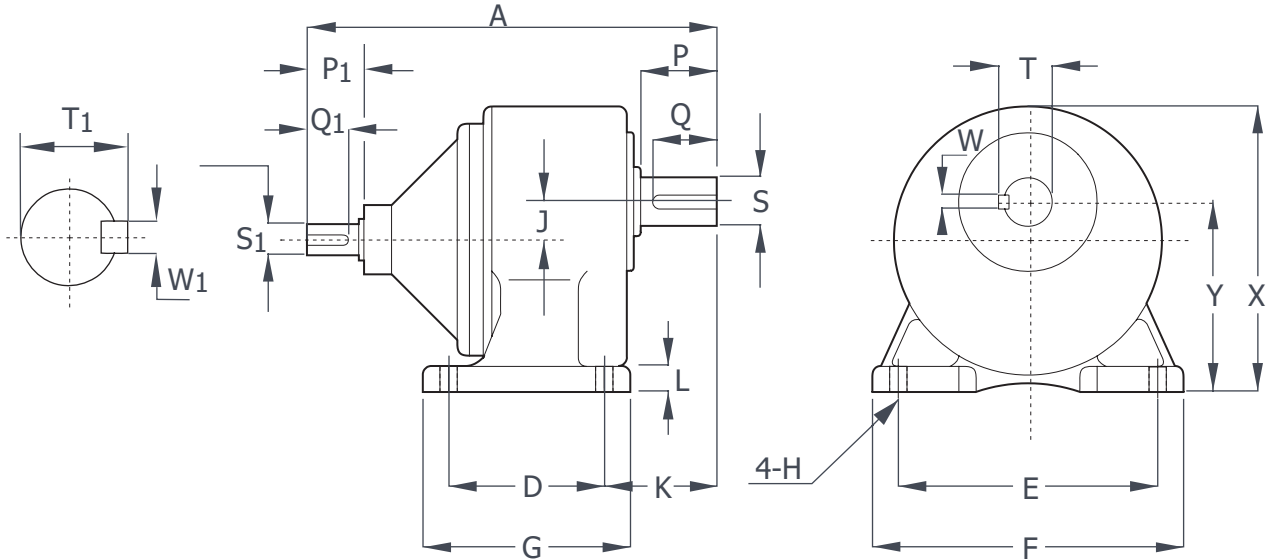
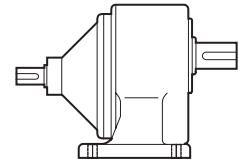

馬力 HP	減速比 Gear Ratio	A	D	E	G	F	H	L	J	K	X	Y	入力軸端 Input Shaft End					出力軸端 Output Shaft End				
													P ₁	Q ₁	S ₁	T ₁	W ₁	P	Q	S	T	W
0.1KW 1/8 HP	5-50	166	40	110	65	135	10	10	16	50	130	85	25	22	11(14)	13.5(17)	4(5)	30	27	18	20	5
	60-200	193	65	130	90	156	11	13	18	55	135	90	25	22	11(14)	13.5(17)	4(5)	40	35	22	25	7
	250-1800	259	90	140	120	170	11	14	22	65	164	110	25	22	11(14)	13.5(17)	4(5)	45	40	28	31	7
0.2KW 1/4 HP	5-10	166	40	110	65	135	10	10	16	50	130	85	25	22	11(14)	13.5(17)	4(5)	30	27	18	20	5
	15-90	193	65	130	90	156	11	13	18	55	135	90	25	22	11(14)	13.5(17)	4(5)	40	35	22	25	7
	100-200	204	90	140	120	170	11	14	22	65	164	110	25	22	11(14)	13.5(17)	4(5)	45	40	28	31	7
	250-1800	288	130	170	167	208	13	17	27	73	197	130	25	22	11(14)	13.5(17)	4(5)	55	50	32	35.5	10
0.4KW 1/2 HP	5-10	201	65	130	90	156	11	13	18	55	135	90	30	27	14	17	5	40	35	22	35	7
	15-90	219	90	140	120	170	11	14	22	65	164	110	30	27	14	17	5	45	40	28	31	7
	100-200	241	130	170	167	208	13	17	27	73	197	130	30	27	14	17	5	55	50	32	35.5	10
	250-1800	243	150	210	198	252	15	18	32.5	93	227	150	30	27	14	17	5	65	60	40	43.5	10
0.75KW 1 HP	5-25	228	90	140	120	170	11	14	22	65	164	110	35	32	19	22	6	45	40	28	31	7
	30-120	260	130	170	167	208	13	17	27	73	197	130	35	32	19	22	6	55	50	32	35.5	10
	125-200	286	150	210	198	252	15	18	32.5	93	227	150	35	32	19	22	6	65	60	40	43.5	10
	250-1800	400	160	230	201	291	18	25	40	100	267	170	35	32	19	22	6	75	70	50	53.5	14
1.5KW 2 HP	5-30	275	130	170	167	208	13	17	27	73	197	130	40	35	24	28	8	55	50	32	35.5	10
	40-100	312	150	210	198	252	15	18	32.5	93	227	150	40	35	24	28	8	65	60	40	43.5	10
	120-200	312	150	210	198	252	15	18	32.5	93	227	150	40	35	24	28	8	65	60	40	43.5	10
	250-900	420	160	230	201	291	18	25	40	100	267	170	40	35	24	28	8	75	70	50	53.5	14
2.2KW 3 HP	5-30	316	160	230	198	252	15	18	32.5	93	227	150	45	40	28	32	8	65	60	40	43.5	10
	40-120	316	160	230	201	291	18	25	40	100	267	170	45	40	28	32	8	75	70	50	53.5	14
3.7KW 5 HP	5-30	425	160	230	201	291	18	25	40	100	267	170	45	40	28	32	8	75	70	50	53.5	14

* All Specifications, dimensions and design characteristics shown in this catalogue are subject to change without notices.

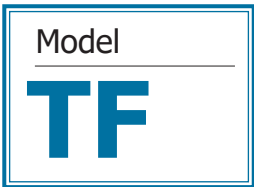

J系列 - 立式雙軸型齒輪減速機

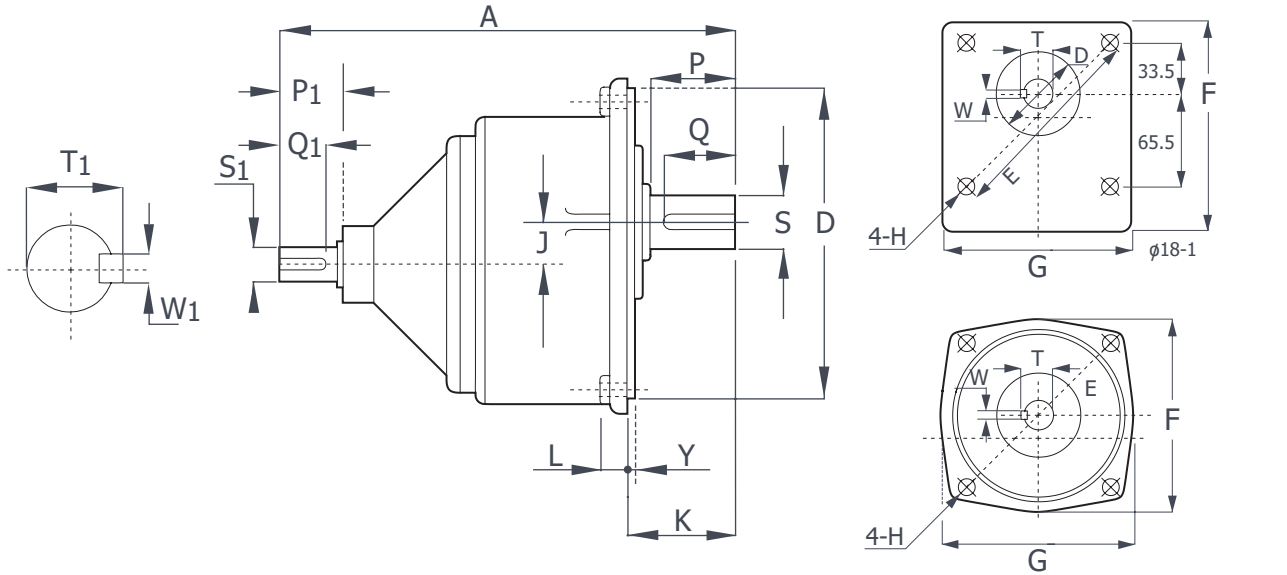

馬力 HP	減速比 Gear Ratio	A	D	E	G	F	H	L	J	Y	K	入力軸端 Input Shaft End					出力軸端 Output Shaft End				
												P ₁	Q ₁	S ₁	T ₁	W ₁	P	Q	S	T	W
0.1kW 1/8 HP	5-50	166	50	140	120	120	10	13	16	4	36	25	22	11(14)	13.5(17)	4(5)	30	27	18	20	5
	60-200	193	148	185	165	165	11	12	18	4	46	25	22	11(14)	13.5(17)	4(5)	40	35	22	25	7
	250-1800	259	170	215	193	198	11	14	22	4	52	25	22	11(14)	13.5(17)	4(5)	45	40	28	31	7
0.2kW 1/4 HP	5-10	166	50	140	120	120	10	13	16	4	36	25	22	11(14)	13.5(17)	4(5)	30	27	18	20	5
	15-90	193	148	185	165	165	11	12	18	4	46	25	22	11(14)	13.5(17)	4(5)	40	35	22	25	7
	100-200	204	170	215	193	198	11	14	22	4	52	25	22	11(14)	13.5(17)	4(5)	45	40	28	31	7
	250-1800	288	180	250	215	230	13	15	27	5	62	25	22	11(14)	13.5(17)	4(5)	55	50	32	35.5	10
0.4kW 1/2 HP	5-10	201	148	185	165	165	11	12	18	4	46	30	27	14	17	5	40	35	22	35	7
	15-90	219	170	215	193	198	11	14	22	4	52	30	27	14	17	5	45	40	28	31	7
	100-200	241	180	250	215	230	13	15	27	5	62	30	27	14	17	5	55	50	32	35.5	10
	250-1800	343	230	310	265	285	15	20	32.5	5	72	30	27	14	17	5	65	60	40	43.5	10
0.75kW 1 HP	5-25	228	170	215	193	198	11	14	22	4	52	35	32	19	22	6	45	40	28	31	7
	30-120	260	180	250	215	230	13	15	27	5	62	35	32	19	22	6	55	50	32	35.5	10
	125-200	286	230	310	265	285	15	20	32.5	5	72	35	32	19	22	6	65	60	40	43.5	10
	250-1800	400	270	360	300	325	22	22	40	5	83	35	32	19	22	6	75	70	50	53.5	14
1.5kW 2 HP	5-30	275	180	250	215	230	13	15	27	5	62	40	35	24	28	8	55	50	32	35.5	10
	40-100	312	230	310	265	285	15	20	32.5	5	72	40	35	24	28	8	65	60	40	43.5	10
	120-200	312	230	310	265	285	15	20	32.5	5	72	40	35	24	28	8	65	60	40	43.5	10
	250-900	420	270	360	300	325	22	22	40	5	83	40	35	24	28	8	75	70	50	53.5	14
2.2kW 3 HP	5-30	316	230	310	265	285	15	20	32.5	5	72	45	40	28	32	8	65	60	40	43.5	10
	40-120	316	270	360	300	325	22	22	40	5	83	45	40	28	32	8	75	70	50	53.5	14
3.7kW 5 HP	5-30	425	270	360	300	325	22	22	40	5	83	45	40	28	32	8	75	70	50	53.5	14

* All Specifications, dimensions and design characteristics shown in this catalogue are subject to change without notices.

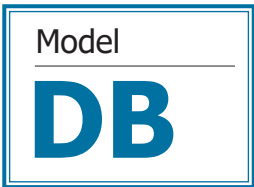

J 系列 - 臥式入力法蘭齒輪減速機

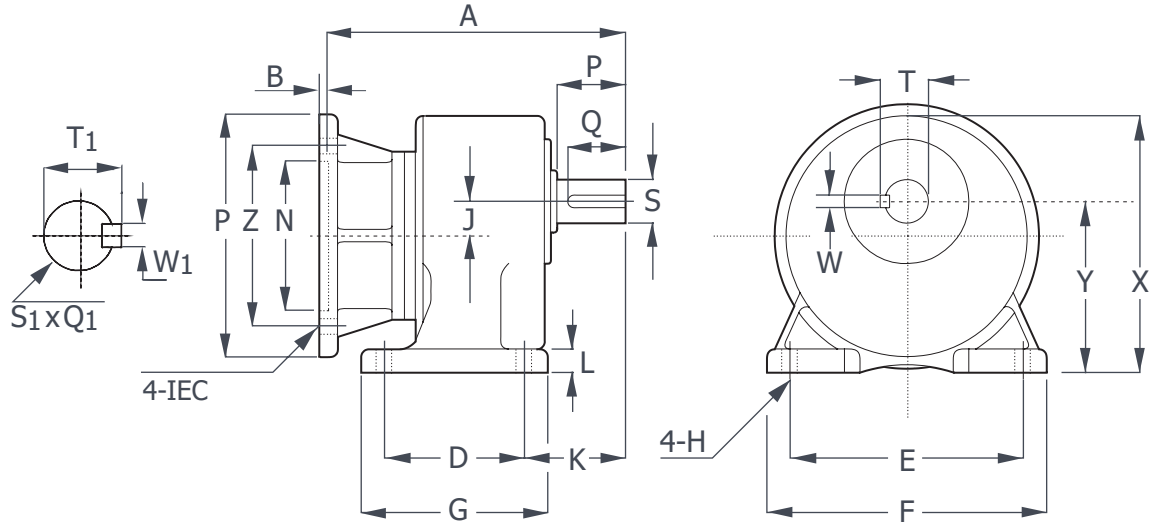
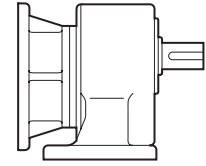

馬力 HP	減速比 Gear Ratio	A	D	E	G	F	H	L	J	K	X	Y	P	Z	N	B	入力軸端 Input Shaft End				出力軸端 Output Shaft End				
																	Q1	S1	T1	W1	P	Q	S	T	W
0.1KW 1/8 HP	5-50	145	40	110	65	135	10	10	16	50	130	85	160	130	110	4.5	33	11(14)	13.5(17)	4(5)	30	27	18	20	5
	60-200	172	65	130	90	156	11	13	18	55	135	90	160	130	110	4.5	33	11(14)	13.5(17)	4(5)	40	35	22	25	7
	250-1800	238	90	140	120	170	11	14	22	65	164	110	160	130	110	4.5	33	11(14)	13.5(17)	4(5)	45	40	28	31	7
0.2KW 1/4 HP	5-10	145	40	110	65	135	10	10	16	50	130	85	160	130	110	4.5	33	11(14)	13.5(17)	4(5)	30	27	18	20	5
	15-90	172	65	130	90	156	11	13	18	55	135	90	160	130	110	4.5	33	11(14)	13.5(17)	4(5)	40	35	22	25	7
	100-200	185	90	140	120	170	11	14	22	65	164	110	160	130	110	4.5	33	11(14)	13.5(17)	4(5)	45	40	28	31	7
	250-1800	267	130	170	167	208	13	17	27	73	197	130	160	130	110	4.5	33	11(14)	13.5(17)	4(5)	55	50	32	31	10
0.4KW 1/2 HP	5-10	172	65	130	90	156	11	13	18	55	135	90	160	130	110	4.5	36	14	17	5	40	35	22	25	7
	15-90	185	90	140	120	170	11	14	22	65	164	110	160	130	110	4.5	36	14	17	5	45	40	28	31	7
	100-200	267	130	170	167	208	13	17	27	73	197	130	160	130	110	4.5	36	14	17	5	55	50	32	31	10
	250-1800	172	150	210	198	252	15	18	32.5	93	227	150	160	130	110	4.5	36	14	17	5	65	60	40	43.5	10
0.75KW 1 HP	5-25	191	90	140	120	170	11	14	22	65	164	110	160	165	130	4.5	42	19	22	6	45	40	28	31	7
	30-120	223	130	170	167	208	13	17	27	73	197	130	200	165	130	4.5	42	19	22	6	55	50	32	35.5	10
	125-200	250	150	210	198	252	15	18	32.5	93	227	150	200	165	130	4.5	42	19	22	6	65	60	40	43.5	10
	250-1800	263	160	230	201	291	18	25	40	100	267	170	200	165	130	4.5	42	19	22	6	75	70	50	53.5	14
1.5KW 2 HP	5-30	236	130	170	167	208	13	17	27	73	197	130	200	165	130	4.5	53	24	28	8	55	50	32	35.5	10
	40-100	273	150	210	198	252	15	18	32.5	93	227	150	200	165	130	4.5	53	24	28	8	65	60	40	43.5	10
	120-200	273	150	210	198	252	15	18	32.5	93	227	150	200	165	130	4.5	53	24	28	8	65	60	40	43.5	10
	250-900	370	160	230	201	291	18	25	40	100	267	170	200	165	130	4.5	53	24	28	8	75	70	50	53.5	14
2.2KW 3 HP	5-30	276	150	210	198	252	15	18	32.5	93	227	150	250	215	180	5	62	28	32	8	65	60	40	43.5	10
	40-120	315	160	230	201	291	18	25	40	100	267	170	250	215	180	5	62	28	32	8	75	70	50	53.5	14
3.7KW 5 HP	5-30	315	160	230	201	291	18	25	40	100	267	170	250	215	180	5	62	28	32	8	75	70	50	53.5	14

* All Specifications, dimensions and design characteristics shown in this catalogue are subject to change without notices.

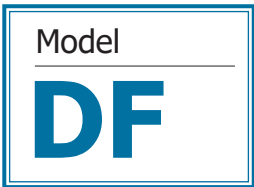

J 系列 - 立式入力法蘭齒輪減速機

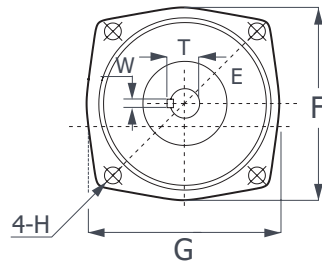
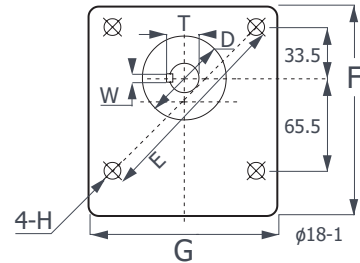
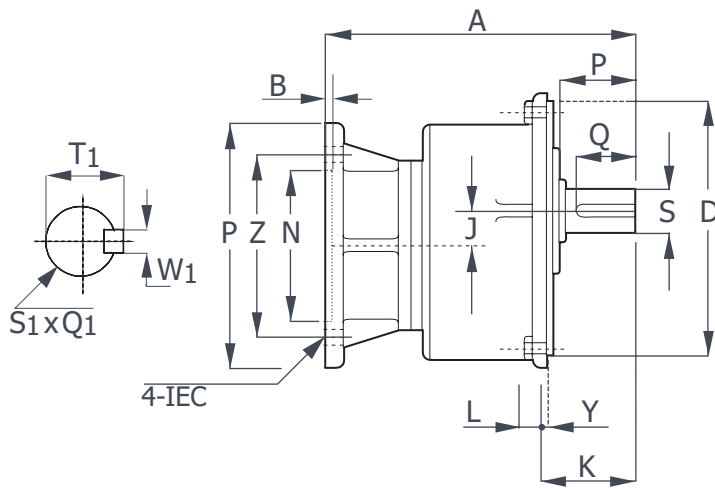
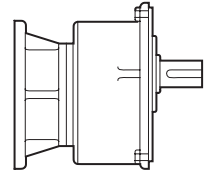

馬力 HP	減速比 Gear Ratio	A	D	E	G	F	H	L	J	Y	K	P	Z	N	B	入力軸端 Input Shaft End				出力軸端 Output Shaft End				
																Q ₁	S ₁	T ₁	W ₁	P	Q	S	T	W
0.1KW 1/8 HP	5-50	145	50	140	120	120	10	13	16	4	36	160	130	110	4.5	33	11(14)	13.5(17)	4(5)	30	27	18	20	5
	60-200	172	148	185	165	165	11	12	18	4	46	160	130	110	4.5	33	11(14)	13.5(17)	4(5)	40	35	22	25	7
	250-1800	185	170	215	193	198	11	14	22	4	52	160	130	110	4.5	33	11(14)	13.5(17)	4(5)	45	40	28	31	7
0.2KW 1/4 HP	5-10	145	50	140	120	120	10	13	16	4	36	160	130	110	4.5	33	11(14)	13.5(17)	4(5)	30	27	18	20	5
	15-90	172	148	185	165	165	11	12	18	4	46	160	130	110	4.5	33	11(14)	13.5(17)	4(5)	40	35	22	25	7
	100-200	185	170	215	193	198	11	14	22	4	52	160	130	110	4.5	33	11(14)	13.5(17)	4(5)	45	40	28	31	7
	250-1800	267	180	250	215	230	13	15	27	5	62	160	130	110	4.5	33	11(14)	13.5(17)	4(5)	55	50	32	31	10
0.4KW 1/2 HP	5-10	172	148	185	165	165	11	12	18	4	46	160	130	110	4.5	36	14	17	5	40	35	22	25	7
	15-90	190	170	215	193	198	11	14	22	4	52	160	130	110	4.5	36	14	17	5	45	40	28	31	7
	100-200	212	180	250	215	230	13	15	27	5	62	160	130	110	4.5	36	14	17	5	55	50	32	31	10
	250-1800	313	230	310	265	285	15	20	32.5	5	72	160	130	110	4.5	36	14	17	5	65	60	40	43.5	10
0.75KW 1 HP	5-25	191	170	215	193	298	11	14	22	4	62	160	165	130	4.5	42	19	22	6	45	40	28	31	7
	30-120	223	180	250	215	230	13	15	27	5	62	200	165	130	4.5	42	19	22	6	55	50	32	35.5	10
	125-200	250	230	310	265	285	15	20	32.5	5	72	200	165	130	4.5	42	19	22	6	65	60	40	43.5	10
	250-1800	263	270	360	300	325	22	22	40	5	83	200	165	130	4.5	42	19	22	6	75	70	50	53.5	14
1.5KW 2 HP	5-30	236	180	250	215	230	13	15	27	5	62	200	165	130	4.5	53	24	28	8	55	50	32	35.5	10
	40-100	273	230	310	265	285	15	20	32.5	5	72	200	165	130	4.5	53	24	28	8	65	60	40	43.5	10
	120-200	273	230	310	265	285	15	20	32.5	5	72	200	165	130	4.5	53	24	28	8	65	60	40	43.5	10
	250-900	370	270	360	300	325	18	22	40	5	83	200	165	130	4.5	53	24	28	8	75	70	50	53.5	14
2.2KW 3 HP	5-30	276	230	310	265	285	15	20	32.5	5	72	250	215	180	5	62	28	32	8	65	60	40	43.5	10
	40-120	315	270	360	300	325	18	22	40	5	83	250	215	180	5	62	28	32	8	75	70	50	53.5	14
3.7KW 5 HP	5-30	315	270	360	300	325	18	22	40	5	83	250	215	180	5	62	28	32	8	75	70	50	53.5	14

* All Specifications, dimensions and design characteristics shown in this catalogue are subject to change without notices.