

LH 臥式減速機馬達

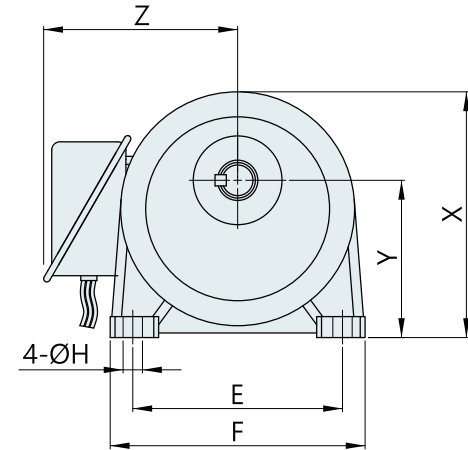
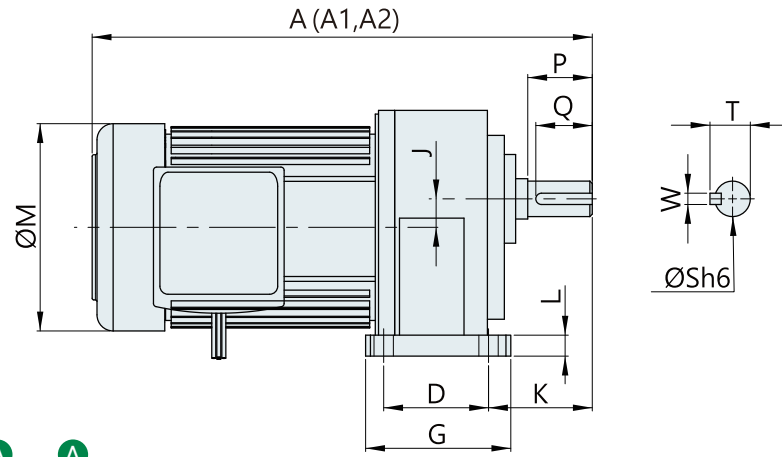

Ⓐ Ⓐ Ⓐ

功率 W (HP)	減速比	本體	框號	A	A1	A2	D	E	F	G	H	J	K	L	M	X	Y	Z	出力軸端				
																			S	P	W	T	Q
100W (1/8 HP)	3-50 (60-200)	1	18	246	276	246	40	110	135	65	9	16	48.6	10	135	131	88.5	120	18	30	5	20	25
	60-200	2	22	276	307	276	65	130	158	90	11	17.65	60	13	135	153	97.5	120	22	40	7	25	35
200W (1/4 HP)	3-10 (12.5-90)	1	18	266	276	276	40	110	135	65	9	16	48.6	10	135	131	88.5	120	18	30	5	20	25
	12.5-90 (100-200)	2	22	296	307	306	65	130	158	90	11	17.65	60	13	135	153	97.5	120	22	40	7	25	35
	100-200	3	28	312	322	322	90	140	180	120	11	24.22	66.5	16	135	174	116	120	28	45	7	31	40
Ⓑ 400W (1/2 HP)	3-10 (12.5-90)	2	22	306	317	-	65	130	158	90	11	17.65	63	13	135	153	97.5	135	22	40	7	25	35
	12.5-90 (100-200)	3	28	322	332	-	90	140	180	120	11	24.22	66.5	16	135	174	116	135	28	45	7	31	40
	100-200	4	32	367	378	-	130	170	210	165	12	30.22	70	20	135	198	130	135	32	55	10	35	50
Ⓒ 400W+ (1/2 HP)	3-10 (12.5-90)	2	22	329	335	358	65	130	158	90	11	17.65	63	13	165	153	97.5	135	22	40	7	25	35
	12.5-90 (100-200)	3	28	353	359	382	90	140	180	120	11	24.22	66.5	16	165	174	116	135	28	45	7	31	40
	100-200	4	32	396	402	418	130	170	210	165	12	30.22	70	20	165	198	130	135	32	55	10	35	50
750W (1 HP)	(3-25)	2	22	336	342	385	65	130	158	90	11	17.65	60	13	165	153	97.5	135	22	40	7	25	35
	3-25 (30-120)	3	28	360	366	410	90	140	180	120	11	24.22	66.5	16	165	174	116	135	28	45	7	31	40
	30-120 (125-200)	4	32	396	402	445	130	170	210	165	12	30.22	70	20	165	198	130	135	32	55	10	35	50
	125-200	5	40	451	457	500	150	210	265	198	15	28	89	22	165	250	162	135	40	65	10	43	60
1500W (2 HP)	(3~40)	3	28	413	413	457	90	140	180	120	11	24.22	66.5	16	192	174	116	135	28	45	7	31	40
	3-30 (40-100)	4	32	453	453	497	130	170	210	165	13	30.22	70	20	192	198	130	146	32	55	10	35	50
	2-100 (110-170)	5	40	510	510	552	150	210	265	198	15	28	89	22	192	250	162	146	40	65	10	43	60
2200W (3 HP)	10-180	6	50	560	560	560	170	265	319	238	18	51	120	31.5	192	308	200	146	50	80	14	54	75
	3-40 (45-80)	5	40	530	530	-	150	210	265	198	15	28	89	22	220	250	162	160	40	65	10	43	60
	45-100	6	50	580	580	-	170	265	319	238	18	51	120	31.5	220	308	200	160	50	80	14	54	75
3700W (5 HP)	3-10 (15-60)	5	40	560	560	-	150	210	265	198	15	28	89	22	220	250	162	160	40	65	10	43	60
	15-60	6	50	620	620	-	170	265	319	238	18	51	120	31.5	220	308	200	160	50	80	14	54	75

★ () 表示輕荷重/縮框機種。輕荷重/縮框機種只限定馬達保固。
★ 單相煞車馬達尺寸另定

Ⓐ A : 三相減速機馬達 / A1 : 三相煞車減速機馬達 / A2 : 單相減速機馬達
Ⓑ 400W 標準型
Ⓒ 400W 單相標準型和三相加強型

1/2HP 三相馬達標準110桶，·如果要加強140桶則價格另議。
1/2HP 三相馬達UL規格，·一律採用140桶。

LV 立式減速機馬達

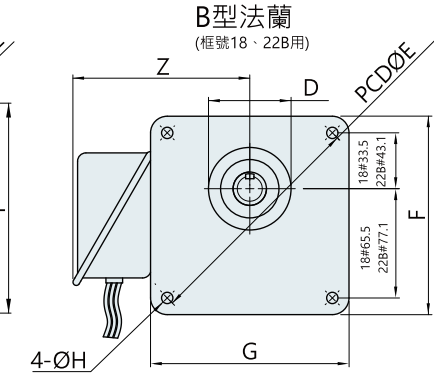
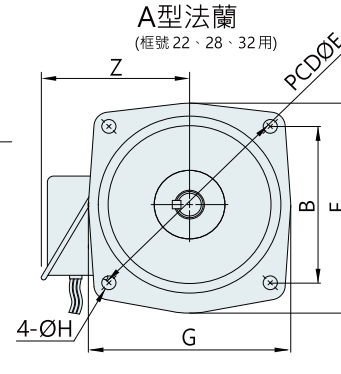
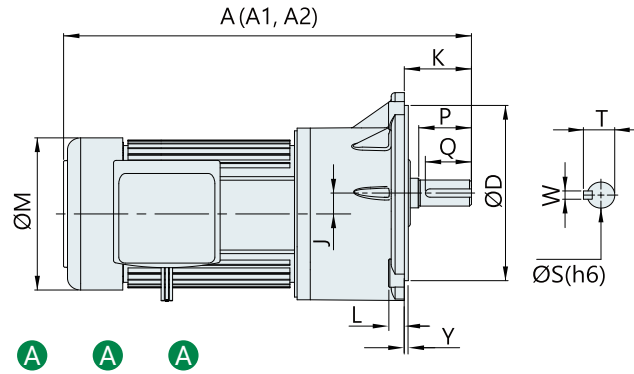

功率 W (HP)	減速比	本體	框號	A	A1	A2	B	D	E	F	G	H	J	K	L	M	Y	Z	出力端軸				
																			S	P	W	T	Q
100W (1/8 HP)	3-50 (60-200)	1	18	246	276	246	-	50	140	119	119	9	16	40	12	135	-	120	18	30	5	20	25
		2	22	276	307	276	130.8	148	185	176	164	11	17.65	47	12	135	3	120	22	40	7	25	35
	60-200	2	22B	276	307	276	-	62	170	147	147	11	17.65	47	12	135	-	120	22	40	7	25	35
200W (1/4 HP)	3-10 (12.5-90)	1	18	266	276	276	-	50	140	119	119	9	16	40	12	135	-	120	18	30	5	20	25
		2	22	296	307	306	130.8	148	185	176	164	11	17.65	47	12	135	3	120	22	40	7	25	35
	12.5-90 (100-200)	2	22B	296	307	306	-	62	170	147	147	11	17.65	47	12	135	-	120	22	40	7	25	35
400W (1/2 HP)	3-10 (12.5-90)	2	22	306	317	-	130.8	148	185	176	164	11	17.65	47	12	135	3	135	22	40	7	25	35
		2	22B	306	317	-	-	62	170	147	147	11	17.65	47	12	135	-	135	22	40	7	25	35
	12.5-90 (100-200)	3	28	322	332	-	155.6	170	220	216	216	11	24.22	60	15	135	6	135	28	45	7	31	40
400W+ (1/2 HP)	3-10 (12.5-90)	2	22	329	335	358	130.8	148	185	176	164	11	17.65	47	12	165	3	135	22	40	7	25	35
		2	22B	339	335	358	-	62	170	147	147	11	17.65	47	12	165	-	135	22	40	7	25	35
	12.5-90 (100-200)	3	28	355	361	384	155.6	170	220	216	216	11	24.22	60	15	165	6	135	28	45	7	31	40
750W (1 HP)	(3-25)	2	22	336	342	385	130.8	148	185	176	164	11	17.65	47	12	165	3	135	22	40	7	25	35
		2	22B	336	342	385	-	62	170	147	147	11	17.65	47	12	165	-	135	22	40	7	25	35
	3-25 (30-120)	3	28	362	368	411	155.6	170	220	216	216	11	24.22	60	15	165	6	135	28	45	7	31	40
	30-120 (125-200)	4	32	396	402	445	180.3	185	255	241	225	13	30.22	65	15	165	4	135	32	55	10	35	50
	125-200	5	40	451	457	500	219.3	230	310	291	272	15	28	85	21	165	5	135	40	65	10	43	60
1500W (2 HP)	(3-40)	3	28	413	413	457	155.6	170	220	216	216	11	24.22	60	15	192	6	135	28	45	7	31	40
		4	32	453	453	497	180.3	185	255	241	225	13	30.22	65	15	192	4	146	32	55	10	35	50
	25-100 (110-170)	5	40	508	508	552	219.3	230	310	291	272	15	28	85	21	192	5	146	40	65	10	43	60
2200W (3 HP)	3-40 (45-80)	5	40	530	530	-	219.3	230	310	291	272	15	28	85	21	220	5	160	40	65	10	43	60
		6	50	580	580	-	275.8	280	390	369	341	18	51	92	25	220	5	160	50	80	14	54	75
3700W (5 HP)	3-10 (15-60)	5	40	560	560	-	219.3	230	310	291	272	15	28	85	21	220	5	160	40	65	10	43	60
		6	50	620	620	-	275.8	280	390	369	341	18	51	92	25	220	5	160	50	80	14	54	75

★ () 表示輕荷重/縮框機種。輕荷重/縮框機種只限定馬達保固。
★ 單相煞車馬達尺寸另定

Ⓐ A: 三相減速機馬達 / A1: 三相煞車減速機馬達 / A2: 單相減速機馬達
Ⓑ 400W 標準型
Ⓒ 400W 單相標準型和三相加強型

1/2HP 三相馬達標準110桶，如果要加強140桶則價格另議。
1/2HP 三相馬達UL規格，一律採用140桶。

LH 臥式高比速減速機馬達

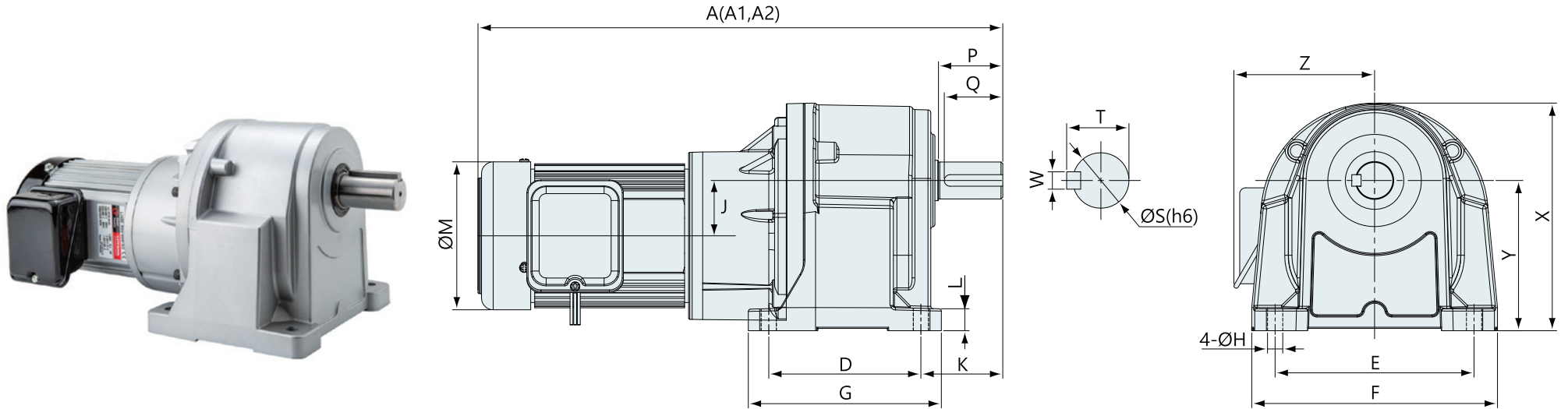

A A A

功率 W (HP)	減速比	本體	框號	A	A1	A2	D	E	F	G	H	J	K	L	M	X	Y	Z	出力軸端				
																			S	P	W	T	Q
100W (1/8HP)	(250-1800)	1# + 2#	22	346	377	346	65	130	158	90	11	33.65	63	13	135	153	97.5	135	22	40	7	25	35
	250-1800	1# + 3#	28	349	379	349	90	140	180	120	11	40.22	66.5	16	135	174	116	135	28	45	7	31	40
200W (1/4HP)	(250-1800)	1# + 3#	28	369	379	379	90	140	180	120	11	40.22	66.5	16	135	174	116	135	28	45	7	31	40
	250-1800	2# + 4#	32	433	444	443	130	170	210	165	13	47.87	70	20	135	198	130	135	32	55	10	35	50
B 400W (1/2HP)	(250-1800)	2# + 4#	32	443	454	-	130	170	210	165	13	47.87	70	20	135	198	130	135	32	55	10	35	50
	250-1800	3# + 5#	40	500	511	-	150	210	265	198	15	52.3	89	22	135	250	160	146	40	65	10	43	60
C 400W+ (1/2HP)	(250-1800)	2# + 4#	32	466	472	495	130	170	210	165	13	47.87	70	20	165	198	130	135	32	55	10	35	50
	250-1800	3# + 5#	40	521	527	550	150	210	265	198	15	52.3	89	22	165	250	160	146	40	65	10	43	60

★ () 表示輕荷重/縮框機種。輕荷重/縮框機種只限定馬達保固。
 ★ 單相煞車馬達尺寸另定
 1/2HP 三相馬達標準110桶，如果要加強140桶則價格另議。
 1/2HP 三相馬達UL規格，一律採用140桶。

A A A
 A: 三相減速機馬達 / A1: 三相煞車減速機馬達 / A2: 單相減速機馬達
 B 400W 標準型
 C 400W 單相標準型和三相加強型

LV 立式高比速減速機馬達

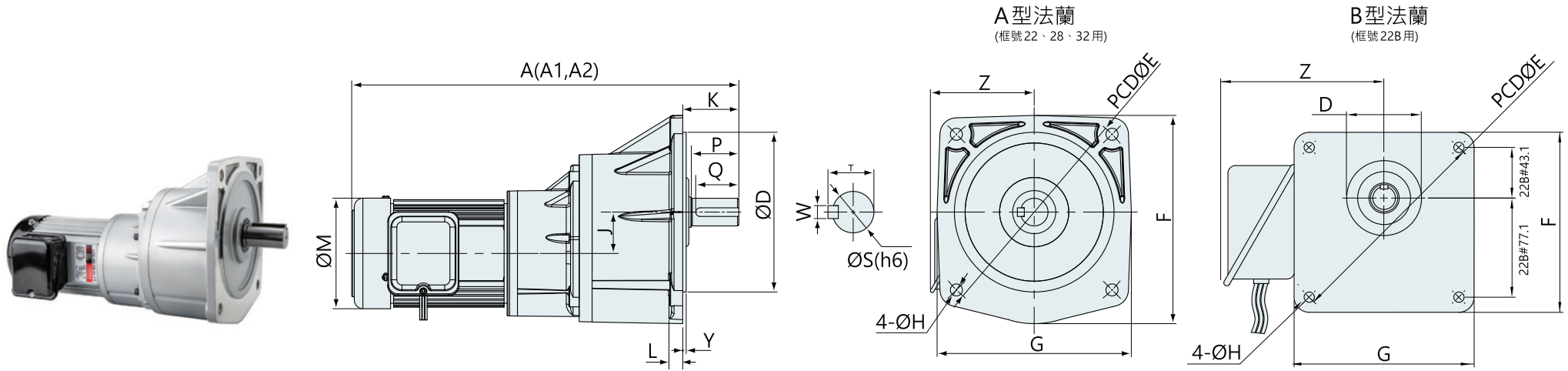

A **A** **A**

功率 W (HP)	減速比	本體	框號	A	A1	A2	D	E	F	G	H	J	K	L	M	Y	Z	出力軸端				
																		S	P	W	T	Q
100W (1/8HP)	(250-1800)	1# + 2#	22	346	377	346	148	185	176	164	11	33.65	47	12	135	3	135	22	40	7	25	35
		1# + 2#	22B	346	377	346	62	170	147	147	11	33.65	47	12	135	-	135	22	40	7	25	35
	250-1800	1# + 3#	28	348	379	348	170	220	216	216	11	40.22	60	15	135	6	135	28	45	7	31	40
200W (1/4HP)	(250-800)	1# + 3#	28	368	379	379	170	220	216	216	11	40.22	60	15	135	6	135	28	45	7	31	40
	250-1800	2# + 4#	32	433	444	443	185	255	241	225	13	47.87	65	15	135	4	135	32	55	10	35	50
400W (1/2HP) B	(250-1800)	2# + 4#	32	443	454	-	185	255	241	225	13	47.87	65	15	135	4	135	32	55	10	35	50
	250-1800	3# + 5#	40	500	511	-	230	310	291	272	15	52.3	85	21	135	5	135	40	65	10	43	60
400W (1/2HP) C	(250-1800)	2# + 4#	32	466	472	495	185	255	241	225	13	47.87	65	15	165	4	135	32	55	10	35	50
	250-1800	3# + 5#	40	521	527	550	230	310	291	272	15	52.3	85	21	165	5	135	40	65	10	43	60

★ () 表示輕荷重/縮框機種。輕荷重/縮框機種只限定馬達保固。

★ 單相煞車馬達尺寸另定

1/2HP 三相馬達標準110桶，如果要加強140桶則價格另議。

1/2HP 三相馬達UL規格，一律採用140桶。

A A：三相減速機馬達 / A1：三相煞車減速機馬達 / A2：單相減速機馬達

B 400W 標準型

C 400W 單相標準型和三相加強型

LHM 臥式入力法蘭減速機

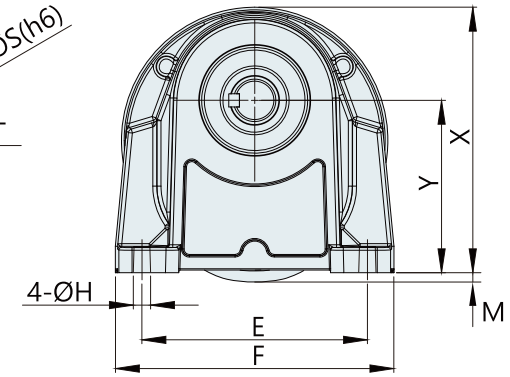
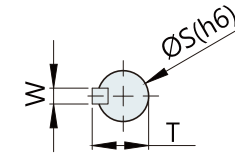
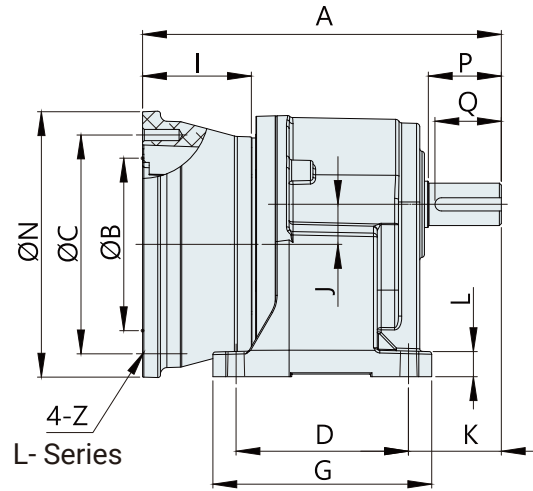
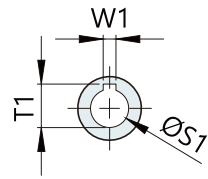

功率 W (HP)	減速比	本體	A	B	C	D	E	F	G	H	I	J	K	L	M	N	X	Y	Z	出力軸尺寸					入力孔尺寸		
																				出力軸端			鍵槽		入力孔鍵槽		
																				S	P	W	T	Q	S1	W1	T1
100W (1/8HP)	3-50 (60-200)	18	156	110	130	40	110	135	65	9	55	16	48.6	10	8	160	131	88.5	M8	Ø18	30	5	20	25	Ø11	4	12.8
	60-200	22	186	110	130	65	130	158	90	11	55	17.65	60	13	1	160	153	97.5	M8	Ø22	40	7	25	35	Ø11	4	12.8
200W (1/4HP)	3-10 (12.5-90)	18	156	110	130	40	110	135	65	9	55	16	48.6	10	8	160	131	88.5	M8	Ø18	30	5	20	25	Ø11	4	12.8
	12.5-90 (100-200)	22	186	110	130	65	130	158	90	11	55	17.65	60	13	1	160	153	97.5	M8	Ø22	40	7	25	35	Ø11	4	12.8
	100-200	28	200	110	130	90	140	180	120	11	55	24.22	66.5	16	-	160	178	116	M8	Ø28	45	7	31	40	Ø11	4	12.8
400W (1/2HP)	3-10 (12.5-90)	22	186	110	130	65	130	158	90	11	55	17.65	60	13	1	160	153	97.5	M8	Ø22	40	7	25	35	Ø14	5	16.3
	12.5-90 (100-200)	28	200	110	130	90	140	180	120	11	55	24.22	66.5	16	-	160	178	116	M8	Ø28	45	7	31	40	Ø14	5	16.3
	100-200	32	247	110	130	130	170	210	165	13	55	30.22	70	20	-	160	216	130	M8	Ø32	55	10	35	50	Ø14	5	16.3
750W (1HP)	3-25 (30-120)	28	235	130	165	90	140	180	120	11	82	24.22	66.5	16	9	200	178	116	M10	Ø28	45	7	31	40	Ø19	6	21.8
	30-120 (125-200)	32	271	130	165	130	170	210	165	13	82	30.22	70	20	1	200	216	130	M10	Ø32	55	10	35	50	Ø19	6	21.8
	125-200	40	326	130	165	150	210	265	205	15	82	28	89	22	-	200	250	160	M10	Ø40	65	10	43	60	Ø19	6	21.8
1500W (2HP)	3-30	32	271	130	165	130	170	210	165	13	82	30.22	70	20	1	200	216	130	M10	Ø32	55	10	35	50	Ø24	8	27.3
	25-100	40	326	130	165	150	210	265	205	15	82	28	89	22	-	200	250	160	M10	Ø40	65	10	46	60	Ø24	8	27.3
2200W (3HP)	3-40	40	336	180	215	150	210	265	198	15	98	28	89	22	-	250	250	160	M14	Ø40	65	10	43	60	Ø28	8	31.3
3700W (5HP)	3-10	40	336	180	215	150	210	265	198	15	98	28	89	22	-	250	250	160	M14	Ø40	65	10	43	60	Ø28	8	31.3

★ () 表示輕荷重/縮框機種。輕荷重/縮框機種只限定馬達保固。

★ 單相煞車馬達尺寸另定

★ 配合 IEC 馬達為準

LVM 立式入力法蘭減速機

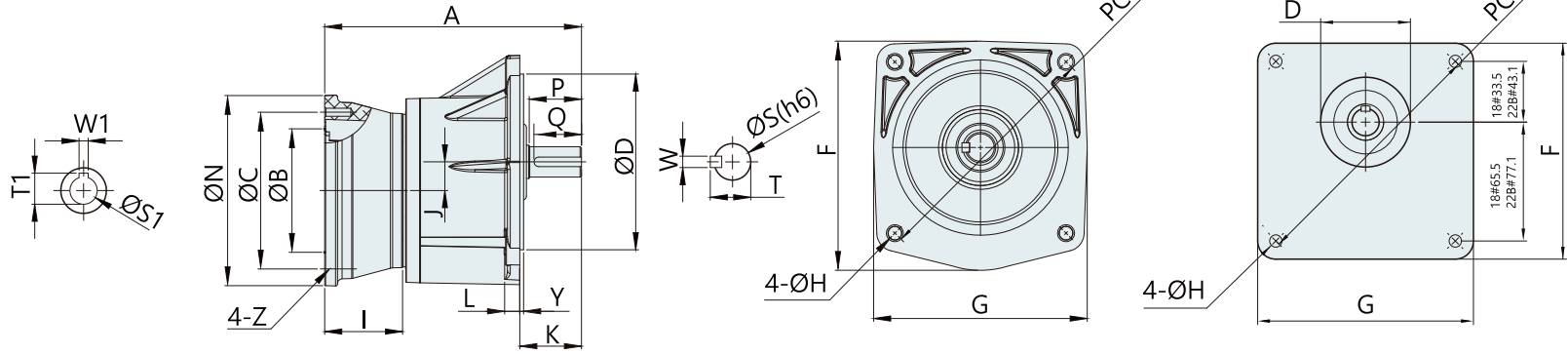

A型法蘭
(框號 22、28、32用)

B型法蘭
(框號18、22B用)

功率 W (HP)	減速比	本體	A	B	C	D	E	F	G	H	I	J	K	L	N	Y	Z	出力軸尺寸					入力孔尺寸		
																		出力軸端		鍵槽			入力孔		鍵槽
																		S	P	W	T	Q	S1	W1	T1
100W (1/8HP)	3-50 (60-200)	18	156	110	130	50	140	119	119	9	55	16	40	12	160	-	M8	Ø18	30	5	20	25	Ø11	4	12.8
	60-200	22	186	110	130	148	185	176	164	11	55	17.65	47	12	160	3	M8	Ø22	40	7	25	35	Ø11	4	12.8
		22B	186	110	130	62	170	147	147	11	55	17.65	47	12	160	-	M8	Ø22	40	7	25	35	Ø11	4	12.8
200W (1/4HP)	3-10 (12.5-90)	18	156	110	130	50	140	119	119	9	55	16	40	12	160	-	M8	Ø18	30	5	20	25	Ø11	4	12.8
	12.5-90 (100-200)	22	186	110	130	148	185	176	164	11	55	17.65	47	12	160	3	M8	Ø22	40	7	25	35	Ø11	4	12.8
		22B	186	110	130	62	170	147	147	11	55	17.65	47	12	160	-	M8	Ø22	40	7	25	35	Ø11	4	12.8
400W (1/2HP)	100-200	28	200	110	130	170	220	216	216	11	55	24.22	60	15	160	6	M8	Ø28	45	7	31	40	Ø11	4	12.8
	3-10 (12.5-90)	22	186	110	130	148	185	176	164	11	55	17.65	47	12	160	3	M8	Ø22	40	7	25	35	Ø14	5	16.3
		22B	186	110	130	62	170	147	147	11	55	17.65	47	12	160	-	M8	Ø22	40	7	25	35	Ø11	4	12.8
750W (1HP)	12.5-90 (100-200)	28	200	110	130	170	220	216	216	11	55	24.22	60	15	160	6	M8	Ø28	45	7	31	40	Ø14	5	16.3
	3-25 (30-120)	32	247	110	130	185	255	241	225	13	55	30.22	65	15	160	4	M8	Ø32	55	10	35	50	Ø14	5	16.3
		22B	247	110	130	62	170	147	147	11	55	17.65	47	12	160	-	M8	Ø22	40	7	25	35	Ø11	4	12.8
1500W (2HP)	30-120 (125-200)	28	235	130	165	170	220	216	216	11	82	24.22	60	15	200	6	M10	Ø28	45	7	31	40	Ø19	6	21.8
	3-30	32	271	130	165	185	255	241	225	13	82	30.22	65	15	200	4	M10	Ø32	55	10	35	50	Ø19	6	21.8
		22B	271	130	165	62	170	147	147	11	82	17.65	47	12	160	-	M8	Ø22	40	7	25	35	Ø11	4	12.8
2200W (3HP)	125-200	40	326	130	165	230	310	290	268	15	82	28	85	21	500	5	M10	Ø40	65	10	43	60	Ø19	6	21.8
	3-30	32	271	130	165	185	255	241	225	13	82	30.22	65	15	200	4	M10	Ø32	55	10	35	50	Ø24	8	27.3
		22B	271	130	165	62	170	147	147	11	82	17.65	47	12	160	-	M8	Ø22	40	7	25	35	Ø11	4	12.8
3700W (5HP)	25-100	40	326	130	165	230	310	290	268	15	82	28	85	21	500	5	M10	Ø40	65	10	43	60	Ø24	6	27.3
	3-40	40	336	180	215	230	310	290	268	15	95	28	85	21	250	5	M14	Ø40	65	10	43	60	Ø28	8	31.3
		22B	336	180	215	62	170	147	147	11	95	17.65	47	12	160	-	M8	Ø22	40	7	25	35	Ø11	4	12.8

- ★ () 表示輕荷重/縮框機種。
- ★ 輕荷重/縮框機種只限定馬達保固。
- ★ 配合 IEC 馬達為準

LHD 臥式雙軸減速機

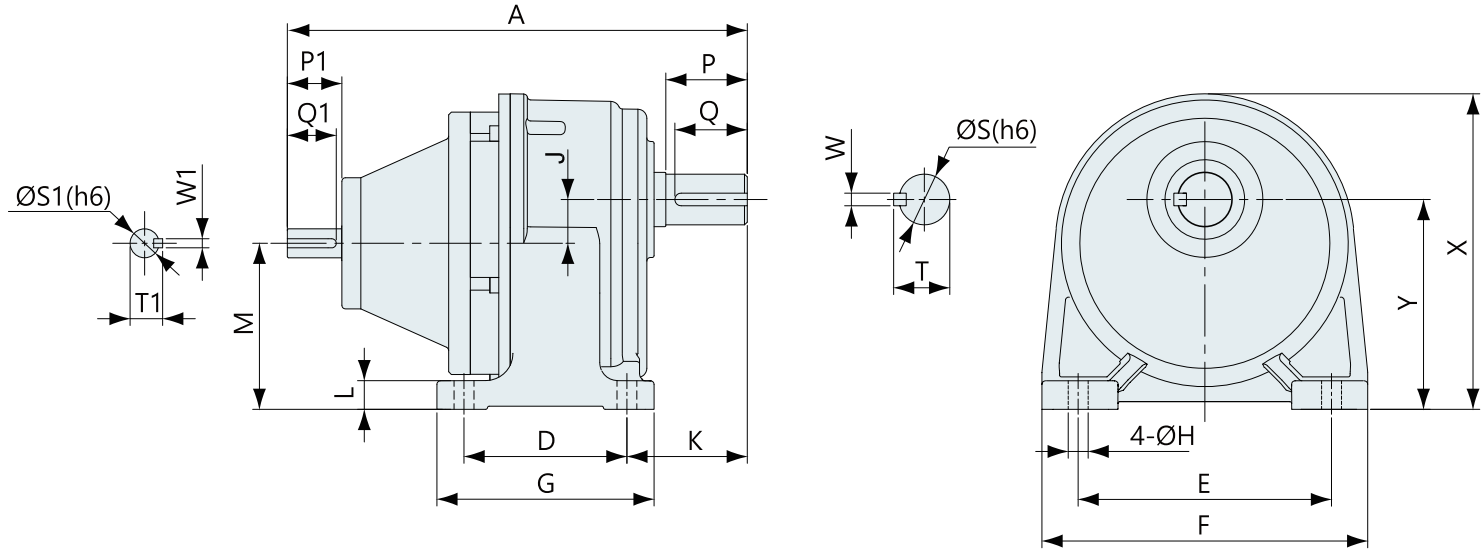

功率 W (HP)	減速比	本體	A	D	E	F	G	H	J	K	L	M	X	Y	出力軸端					入力軸端				
															S	P	W	T	Q	S1	P1	W1	T1	Q1
100W (1/8HP)	3-50 (60-200)	18	165	40	110	135	65	9	16	48.6	10	72.5	131	88.5	18	30	5	20	25	14	25	5	16	22
	60-200	22	196	65	130	158	90	11	17.65	60	13	80	153	97.5	22	40	7	25	35	14	25	5	16	22
200W (1/4HP)	3-10 (12.5-90)	18	165	40	110	135	65	9	16	48.6	10	72.5	131	88.5	18	30	5	20	25	14	25	5	16	22
	12.5-90 (100-200)	22	196	65	130	158	90	11	17.65	60	13	80	153	97.5	22	40	7	25	35	14	25	5	16	22
	100-200	28	210	90	140	180	120	11	24.22	66.5	16	92	174	116	28	45	7	31	40	14	25	5	16	22
	3-10 (12.5-90)	22	230	65	130	158	90	11	17.65	60	13	80	153	97.5	22	40	7	25	35	16	30	5	18	27
400W (1/2HP)	12.5-90 (100-200)	28	255	90	140	180	120	11	24.22	66.5	16	92	174	116	28	45	7	31	40	16	30	5	18	27
	100-200	32	290	130	170	210	165	13	30.22	70	20	100	198	130	32	55	10	35	50	16	30	5	18	27
750W (1HP)	3-25 (30-120)	28	265	90	140	180	120	11	24.22	66.5	16	92	174	116	28	45	7	31	40	19	40	6	21.5	35
	30-120 (125-200)	32	300	130	170	210	165	13	30.22	70	20	100	198	130	32	55	10	35	50	19	40	6	21.5	35
1500W (2HP)	3-30	32	310	130	170	210	165	13	30.22	70	20	100	198	130	32	55	10	35	50	24	50	8	27	45

- ★ () 表示輕荷重/縮框機種。
- ★ 輕荷重/縮框機種只限定馬達保固。

LVD 立式雙軸減速機

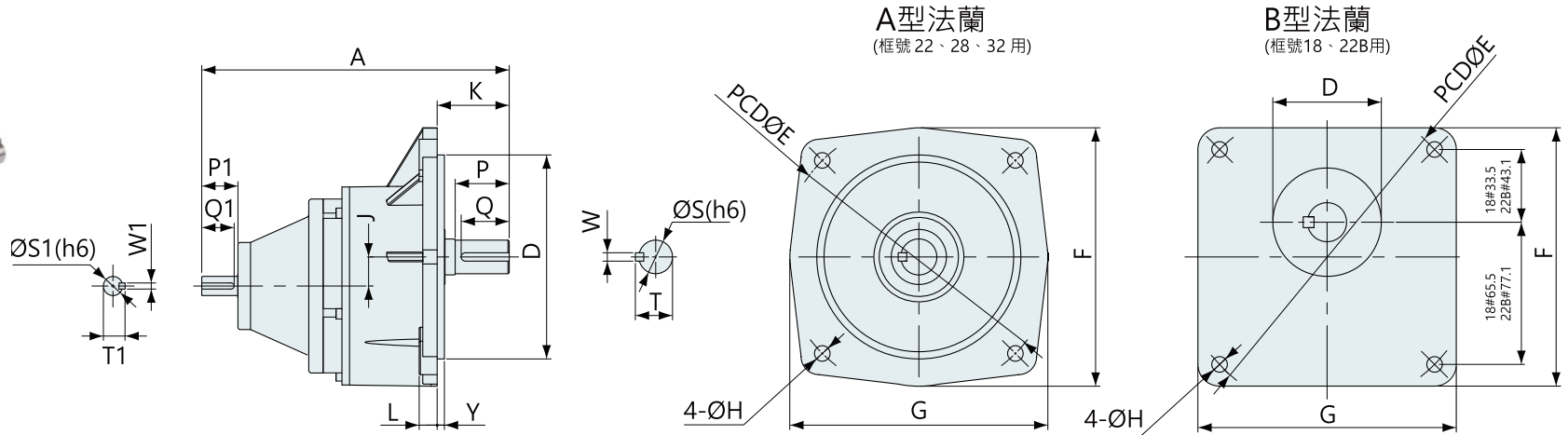

功率 W (HP)	減速比	本體	A	D	E	F	G	H	J	K	L	Y	出力軸端					入力軸端				
													S	P	W	T	Q	S1	P1	W1	T1	Q1
100W (1/8HP)	3-50 (60-200)	18	166	50	140	119	119	9	16	40	12	-	18	30	5	20	25	14	25	5	16	22
	60-200	22	196	148	185	176	164	11	17.65	47	12	3	22	40	7	25	35	14	25	5	16	22
		22B	196	62	170	147	147	11	17.65	47	12	--	22	40	7	25	35	14	25	5	16	22
200W (1/4HP)	3-10 (12.5-90)	18	166	50	140	119	119	9	16	40	12	-	18	30	5	20	25	14	25	5	16	22
	12.5-90 (100-200)	22	196	148	185	176	164	11	17.65	47	12	3	22	40	7	25	35	14	25	5	16	22
		22B	196	62	170	147	147	11	17.65	47	12	-	22	40	7	25	35	14	25	5	16	22
400W (1/2HP)	3-10 (12.5-90)	28	210	170	220	216	216	11	24.22	60	15	6	28	45	7	31	40	14	25	5	16	22
		22	230	148	185	176	164	11	17.65	47	12	3	22	40	7	25	35	16	30	5	18	27
	12.5-90 (100-200)	22B	230	62	170	147	147	11	17.65	47	12	-	22	40	7	25	35	16	30	5	18	27
		28	255	170	220	216	216	11	24.22	60	15	6	28	45	7	31	40	16	30	5	18	27
750W (1HP)	3-25 (30-120)	32	290	185	255	241	225	13	30.22	65	15	4	32	55	10	35	50	16	30	5	18	27
	30-120 (125-200)	28	265	170	220	216	216	11	24.22	60	15	6	28	45	7	31	40	19	40	6	21.5	35
1500W (2HP)	3-30	32	300	185	255	241	225	13	30.22	65	15	4	32	55	10	35	50	19	40	6	21.5	35
1500W (2HP)	3-30	32	310	185	255	241	225	13	30.22	65	15	4	32	55	10	35	50	24	50	8	27	45

★ () 表示輕荷重/縮框機種。
 ★ 輕荷重/縮框機種只限定馬達保固。